

RPHmdp – Process pump to API685



Applications:

For handling aggressive, toxic, explosive, valuable, inflammable or hazardous liquids in the chemical, petrochemical and general industries

More information:

www.ksb.com/products

RPHmdp – Process pump to API685

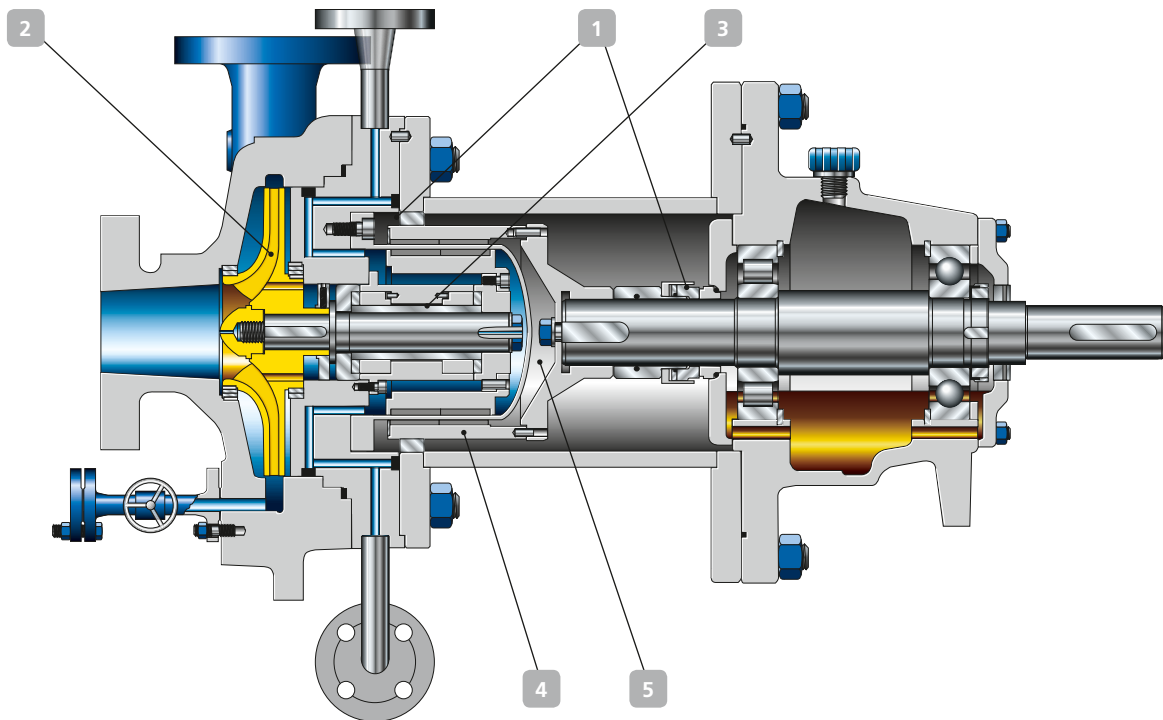

1 Maximum safety

- Zero emission or leakage to the environment
- Secondary containment with additional mechanical seal for optimal safety

2 Proven success

- Thanks to the RPH hydraulic system
- Fully interchangeable with RPH

3 Maximum availability

- Magnetic coupling reduces maintenance requirement and probability of failure

4 Little maintenance

- Perfectly balanced rotor makes for low vibration levels
- Fitted with product-lubricated bearings made of silicon carbide composite
- Patented, grooved axial bearings design for heat dissipation and particle removal in magnetic drive

5 Saving energy

- Through high efficiency magnetic drives (reduces eddy current-losses to a minimum)
- Through PEEK carbon fibre containment shell (option available) no eddy current-losses

Materials

S1, S5, S6, S8, C6, A8, D1, D2 and special materials

Technical data

Pump size	DN 25 – 100
Flow rate	Up to 300 m ³ /h
Head	Up to 270 m
Discharge pressure	Up to 51 bar
Fluid temperature	-40 °C to +300 °C
Certification	ATEX, CE and EAC approved



KSB Aktiengesellschaft
 Johann-Klein-Straße 9
 67227 Frankenthal (Germany)
 www.ksb.com